

## Auto Lathe

### T Series

#### **Specifications:**

Model	RC-42T	RC-42MT	RC-42i	
<b>SPEC.</b>	Swing Over Bed	380 mm		
	Over Cross Slide	225 mm		
	Max. Turning Diameter	225 mm	270 mm	100 mm
	Max. Turning Length	320 mm	300 mm	330 mm
	Chuck Size	6 / 8 inch Opt.	6 inch	6 / 8 inch Opt.
	Spindle Nose	A2-5 / A2-6	A2-5	A2-5 / A2-6
	Through Spindle Hole Dia.	51 / 62 mm	51 mm	51 / 61 mm
	Draw Tube Dia.	45 / 52 mm	45 mm	45 / 52 mm
	Front Bearing Dia.	80 / 100 mm	80 mm	80 / 100 mm
	X-Axis Travel	142 mm		360 mm
	Z-Axis Travel	325 mm		350 mm
	Guideway Type	Linear Rail		
	Max. Spindle Speed	6000 / 4500 rpm	4500 rpm	6000 / 4500 rpm
	Max. Power Tool Speed	-	4000 rpm	-
	No. of Tool Positions	8T / 12T	12T	-
	O.D. Tool	20 / 16 Opt.	16	-
	Boring Bar Dia.	32 / 25 Opt.	25	-
	Rapid Traverse	X24 / Z24 m/min		X30 / Z30 m/min
	Cutting Feed	1.26 m/min		-
	Positioning	±0.005		-
	Repeatability	±0.002		-
	Quill Dia.	58		-
	Quill Taper	MT-4		-
	Quill Travel	88 mm		-
	Gang Type Tool Capacity	-	-	4
	Spindle Motor	5.5 / 7.5 kw		
	X、 Z-Axis Motor	X=1.5 kw、 Z=1.5 kw		
	Power Too Motor	-	1.5 / 2.2 kw	-
	Power	21 kva		32 kva
	Coolant Tank Capacity	125 L		
Machine Dimension	1800 x 1450 mm			
Machine Weight (N.W.)	3300 kg		3000 kg	

Standard Accessories		
3 Jaw Hydraulic Chuck	Chip Conveyor (Include Cart)	Coolant Pump Unit
Hydraulic System	3 Step Light	U-Drill Tool Holder Cover
▼▼▼▼Hydraulic Tailstock (RC-42T/42MT ONLY)	Heat Exchanger	Boring Bar Holder Cover
Auto Lubrication System	Boring Bar Holder & Sleeve	Tool Box
Working Light	Facing Tool Holder	
Optional Accessories		
Collet Chuck and Collets	Auto Door	Safety Torque Limit Clutch
Barfeeder	CE Mark	Transformer
Parts Catcher	Tool Setter	Air Condition

## Tooling Interference Diagram

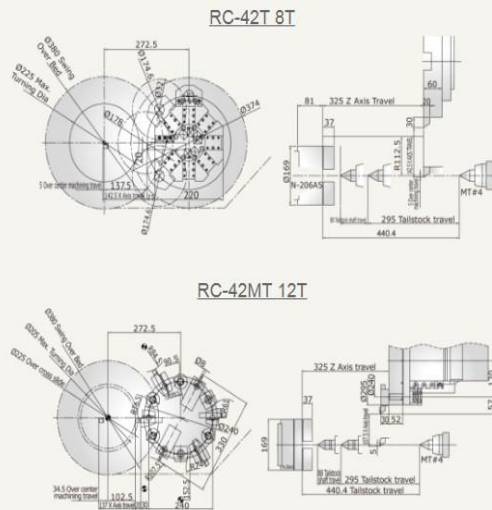

## Dimension

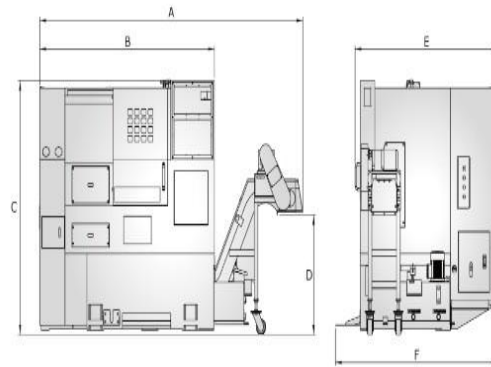

Model	A	B	C	D	E	F
RC-42T	2712	1800	1644	775	1470	1673

## Body Structure

**Position for chuck trip detection.**

**Easy M/C movement**

- If workpiece too long, could mount thimble to withstand which clamping by chuck. Also could through hydraulic solenoid valve to adjust thimbles pressure.

- Widely spaced guideways of the X and Z-axis are 187mm and 250mm respectively.

- Built-in coolant nozzles and channels are also providing in the turret disc.